

- First prevailing-off torque is an indication of locking torque and resistance to vibrational loosening and was judged favorably high for EXTRUDE-TITE® screws in thin sheet metal.
- Performance in extruded holes is slightly higher than in drilled holes. Therefore, either hole design is favorable.
- EXTRUDE-TITE® screws typically forward and backward extrude material beyond its original thickness, providing the fastener with over twice the engagement than that of non-extruded materials.
- An important consideration is the significantly superior and consistent strip-to-drive ratio of EXTRUDE-TITE® screws over other sheet metal screws which allows for more liberal driver clutch settings at the fastening site.
- Tests have shown that EXTRUDE-TITE® fasteners may be used in a wide range of pilot hole sizes with satisfactory results depending upon application requirements.
- May be used in thicker materials as a thread-forming, locating point fastener.
- Couple EXTRUDE-TITE® fasteners with an underhead locking feature for ultimate vibrational and 'spin-out' resistance or with a sharp point to pierce cloth, vinyl or other such similar materials.

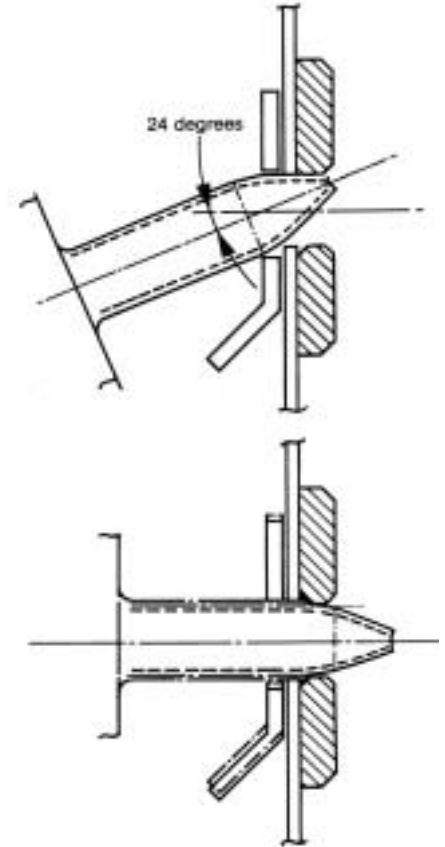

Self-aligning point feature 'finds' the holes, lines them up and fastens components in one operation.

Description	Material Thickness	Hole Size	Drive Torque	First Prevailing Off Torque	Strip Torque	Strip to Drive Ratio	Recommended Tightening Torque
#6 - 32 x 3/8	0.028	0.080	4	2	12	3:1	8
Hex Washer Head	0.032	0.080	5	3	15	3:1	10
Zinc & Wax	0.040	0.080	7	3	21	3:1	14
#8 - 32 x 3/8	0.028	0.110	5	2	15	3:1	10
Hex Washer Head	0.032	0.110	6	3	18	3:1	12
Zinc & Wax	0.040	0.110	10	4	26	2.6:1	18
#10 - 32 x 9/16	0.028	0.138	8	3	25	3:1	17
Hex Washer Head	0.032	0.138	10	4	29	3:1	20
Zinc & Wax	0.040	0.138	15	11	45	3:1	30
1/4 - 20 x 5/8	0.028	0.181	12	6	35	3:1	24
Hex Washer Head	0.032	0.181	14	7	36	2.6:1	25
Zinc & Wax	0.040	0.181	21	10	57	2.7:1	39
M4 x 0.7 x 13	0.70	2.64	0.90	0.32	2.18	2.4:1	1.54
Hex Washer Head	0.80	2.64	1.13	0.39	2.35	2:1	1.74
Zinc & Wax	1.00	2.64	1.32	0.52	2.71	2:1	2.02
M5 x 0.8 x 16	0.70	3.45	0.93	0.35	2.59	2.8:1	1.76
Hex Washer Head	0.80	3.45	1.11	0.73	3.55	3:1	2.33
Zinc & Wax	1.00	3.45	1.66	1.40	4.82	3:1	3.24
M6 x 1.0 x 16	0.70	4.60	1.09	0.48	3.71	3.4:1	2.40
Hex Washer Head	0.80	4.60	1.32	0.52	3.79	3:1	2.56
Zinc & Wax	1.00	4.60	2.12	0.92	6.17	3:1	4.15

TEST PARAMETERS -

- Test material: cold-rolled draw quality aluminum killed steel plate hardened to Rb 50-55
- Test washer: .063 thick steel
- Clearance hole: .180(#6), .200(#8), .220(#10), .280(1/4")
- Drive speed: 250 RPM under load
- Driver end load: 8lbs.

- These values may vary proportionately to application. Smaller hole sizes, for example, will increase drive, first off, strip torques, etc. Material thickness will also effect torque/tension values as indicated in the table. These values were derived from averages of over 1800 laboratory tests under specific conditions. These values are to be used only as a guide since actual application performance results may vary.